

Techcon Systems

TS1258

Pressure Pot

User Guide

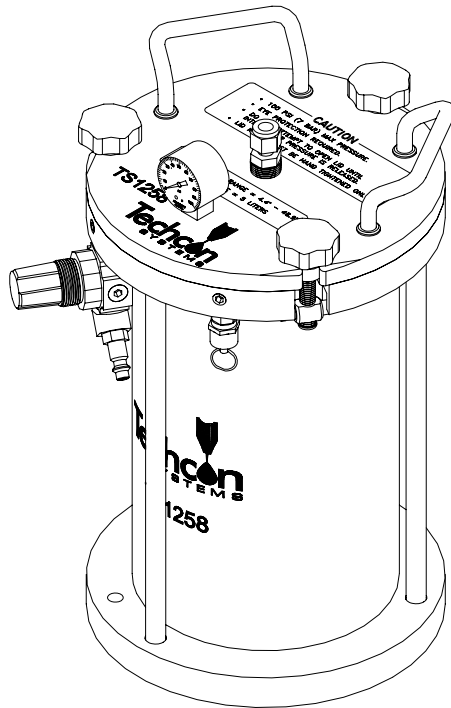

TABLE OF CONTENT

1. SAFETY.....	3
1.1 Intended Use	3
1.2 Safety Precaution	3
2. CERTIFICATE OF CONFORMANCE.....	4
3. FEATURES	5
4. SPECIFICATIONS	5
5. INSTALLATION AND OPERATION.....	6
5.1 Connector and Tubing Installation	6
5.2 Setup Procedure	6
5.3 Start-Up Procedure	8
5.4 Remove Old Tubing	9
6. ACCESSORIES AND SPARE PARTS	11
6.1 O-rings	11
6.2 Fitting and Tubing Kits	11
6.3 Parts List	12
7. WARRANTY	13

1. SAFETY

1.1 Intended Use:

WARNING: *Use of this equipment in ways other than those described in this User Guide may result in injury to persons or damage to property. Use this equipment only as described in this User Guide.*

OK International cannot be responsible for injuries or damages resulting from unintended applications of its equipment. Unintended uses may result from taking the following actions:

- Making changes to equipment that has not been recommended in the User Guide
- Using incompatible or damaged replacement parts
- Using unapproved accessories or auxiliary equipment

This User Guide is designed to provide information about the OK International hardware. Every effort has been made to make this manual as complete and accurate as possible. There is no implied or expressed warranty as to the purpose, suitability or fitness of the information. The information is provided on an as-is basis. OK International, Inc. reserves the right to improve and revise its products. This manual specifies and describes the product, as it existed at the time of publication.

1.2 Safety Precautions:

- Do not apply more than 100 psi (6.9 bar) pressure
- Eye protection is required
- Do not attempt to open coverlid until air pressure is released
- Cover knobs must be hand tightened ONLY
- Secure the pressure Pot to bench top or other stable work surface
Model TS1258 has mounting holes in base plate
- Check with Factory if unsure about dispensing material chemical compatibility
- Read the material safety data sheets for special precautions for the specific material being dispensed. Wear protective safety equipment as specified in the material safety data sheets.

2. CERTIFICATE OF CONFORMITY

CERTIFICATE OF CONFORMITY

Model: TS1258 Serial Number:

We hereby certify that this Pressure Pot conforms to Category B of the Simple Pressure Vessels Directive 87/404/EEC. It has a PSV below 50 bar/litres and must not be CE marked.

It has been pressure tested by OK International, Inc. to: 7.58 bar (110psi) for a maximum working pressure of: 7 bar (100psi). Always follow the user instructions and do not exceed the maximum working pressure.

3. FEATURES

- Compatible with UV cured adhesives with O-Ring Kit # TS1258EPR
- Up to 100 psi operating pressure
- Durable stain resistant finish
- Disposable polyethylene tubing
- Integrated on/off valve and controller available
- Relief Valve with pull ring to depressurize after dispense operation
- One continuous tube for fluid dispensing from container to valve
- Three different tubing and fitting sizes (3/8" O.D, 1/4" O.D and 4 mm)
- Easy to replace, disposable polyethylene tubing after dispense operation
- No material contact with tube fittings
- No cleaning required after dispense operation
- Two O-Ring materials provided for different material applications (Viton, EPR/EPDM)

4. SPECIFICATIONS

Size:	9"(22.9cm) x 11"(27.9cm) x 15"(38.1cm)
Chamber:	6"(15.2cm) I.D. x 11"(27.9cm)
Internal Volume:	5 liters
Weight:	21 lbs (9.5 kg)
Temperature Range:	40 °F (4.4 °C) – 120 °F (48.9 °C)
Operating Pressure:	100 psi (6.9 bar) max.
Tube Sizes:	TS1258-250....Accessory kit 1/4" fitting and tubing
Options Available:	NEED TO BUY TUBE KIT TS1258-375.....Accessory kit 3/8" fitting and tubing TS1252-4MM...Accessory kit 4mm fitting and tubing

5. INSTALLATION AND OPERATION

5.1 Connector and Tubing Installation

1. Select dispense size Tubing and Male Connector with Ferrule
2. Three tubing sizes are available:
 - A. 3/8" diameter
 - B. 1/4" diameter
 - C. 4mm diameter
3. Install selected size Male Connector on the Lid by screwing into the 3/8-18 NPT female threads. Note: Use Teflon tape on connector threads
4. Unscrew the Nut only off the Male Connector. Remove the front & back Ferrule
5. Insert selected size Tubing through the Nut and the back and front parts of the Ferrule
6. Insert the Tubing assembly end into the Male Connector body and loosely screw the Nut back on the Connector body

5.2 Setup Procedure

1. Insure pressure regulator is off (set at zero). Pull locked regulator knob out to unlock and turn counterclockwise several rotations to set to zero psi
2. Turn three locking knobs counterclockwise to remove cover. Unscrew each locking knob until it is able to flip over its hinge to clear the cover plate
3. Remove cover of the 1258 Pressure Pot using the two handles on top and carefully set it aside
4. Remove cap from material container. Cap may be saved for future resealing of the container
5. Place material container inside pressure pot chamber
6. Insure that the O'Ring stays in the groove of the cover
7. Insure the connector tubing installation is complete as described in Section 5.1 Connector and Tubing Installation. Nut on the connector body should be very loose to enable easy movement of tube through the connector body on the cover

NOTE: Do not pour or spill dispense material into Pressure Pot chamber.



Figure 1 Air connection to Pressure regulator



Figure 2 Insert air hose to clip at the base of pressure pot

8. Install cover on the Pressure Pot making sure to direct tube end into opened container with dispense material/fluid
9. Align the three slots on the cover with the three knobs.
10. Lift the three locking knobs into slots on the cover and tighten the three locking knobs uniformly until snug. (Hand Tight Only)
11. Push tubing through the connector fitting on cover further into dispense fluid until it touches the bottom of container. Relying on feel only, pull the tubing to retract about 1/4" from the bottom of the container as shown in Figure 3

12. Hand tightens the nut securely onto the connector body. Try to pull on the tube to insure the ferrule is holding the tube securely in the connector
13. Make necessary connection at the dispense end of the tube.
14. Attached the other end of the tube to a dispense valve
15. Connect air hose from filtered source to the quick male connector air inlet fitting as shown in Figure 1
16. Insert air hose to clip of pressure pot as shown in Figure 2

WARNING: Never pour adhesives or other material directly into dispenser. To do so may cause severe damage to dispenser. Use material container or similar containment vessel.

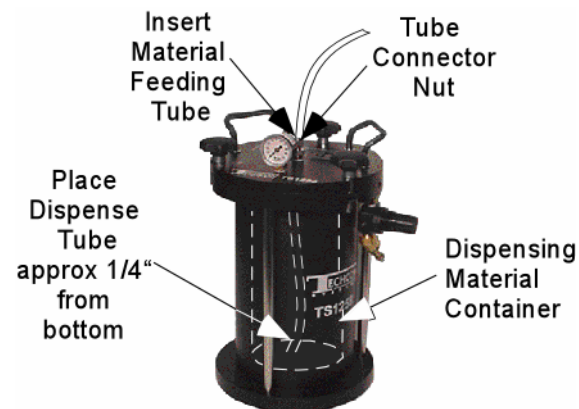

Figure 3 Material Feeding Tube Insertion

Note: Dispense tube must be attached to Dispensing Device (such as TS1201 Dispense Pen, TS1212 Micro Shot Valve or equivalent).

5.3 Start-Up Procedure

1. Pull pressure regulator knob and turn clockwise to increase air pressure to the desired operating pressure. Insure that the pressure gauge reading does not exceed 100 psi maximum. Then push regulator knob in to lock and maintain set gage pressure

WARNING: Always start at lowest pressure and gradually increase as needed.

2. Listen for any possible air pressure leakage on the Pressure Pot
3. Look for any signs of material/fluid leakage on tubing

Note: Pressure Pot Setup is now complete and ready for dispensing operation with the selected valve system.



Figure 4 Relief Valve

WARNING: Whenever replacing or removing valve (s) insure that regulator is at zero. Do not open lid until air pressure is at zero

5.4 Remove old Tubing

1. Pull air pressure regulator knob, turn counterclockwise and lower air pressure to zero
2. Pull on Relief Valve (figure 4) to insure chamber is completely depressurized.
3. Disconnect air supply line if necessary
4. Disconnect fluid tubing from dispense valve

Note: Hold the fluid tubing in vertical position to allow fluid inside tubing to flow back inside bottle/container.

5. Loosen the 3 lid knobs slowly and evenly. If excessive effort is required, insure air pressure gauge reading is zero
6. Unscrew tube male connector nut completely. Move nut and ferrule along tubing about 4 inches away from the connector body on the cover
7. Cut off tubing in between connector body on lid and nut/ferrule. Put the cut tubing with nut/ferrule aside. Take care to accommodate drainage and spillage at the end of tubing
8. Wipe off any excess fluid material from the cut-ends of the tubing's
9. Remove nut and ferrule parts from the used tube
10. Remove cover from Pressure Pot using the two handles, while carefully pulling used tubing half from the container, and set aside. Be careful to avoid splashing and spillage from the tube end in the material container/bottle
11. Using a disposable hand glove or tongs, carefully pull the used-up tube from the connector body on the Lid. Pull tubing from the inner side of cover plate. Dispose used tubing appropriately
12. Screw the nut on the connector body. Ferrule parts may be replaced
13. Disconnect fitting on the dispense end of tubing, and discard used tube

NOTE: New tubing is required for the next dispensing operation.

6. ACCESSORIES AND SPARE PARTS

6.1 O-Rings

The Installed O-Ring: The standard O-Ring supplied on your Pressure Pot is made of Viton and is intended for applications with Lubricants, Conductive and Non-Conductive Adhesives, and various other compounds not listed below. This O-Ring may be cleaned with Toluene and/or Isopropyl Alcohol.

WARNING: DO NOT soak O-Ring in Toluene, MEK, and Acetone. Read material safety data sheet for any solvent prior to use.

Spare O-ring: A Kit is available made of EPR and is intended for applications using fluids containing UV Adhesives, Cyanoacrylates (CA's), Methacrylates, and/or Acrylic Acids. If used, this O-Ring may be cleaned as necessary with Isopropyl Alcohol, Acetone, and MEK.

Please Note: Occasionally an EPR O-ring will swell or degrade when in contact with some UV Adhesives, Cyanoacrylates (CA's), Methacrylates, and/or Acrylic Acids. This might be due to other components in the fluid product. In these cases we recommend switching to the Viton O-Ring which will then perform better with this type of fluid.

PART NUMBER	DESCRIPTION
TS1258-EPR	O-RING KIT EPR
TS1258-VITON	O-RING KIT VITON

6.2 Fitting And Tubing Kits

There are three tubing sizes can be used with the TS1258 pressure pot, below are part numbers:

PART NUMBER	DESCRIPTION
TS1258-375	ACCESSORY KIT 3/8", FITTING & TUBING
TS1258-250	ACCESSORY KIT 1/4", FITTING & TUBING
TS1252-4MM	ACCESSORY KIT 4MM, FITTING & TUBING

6.3 Parts List

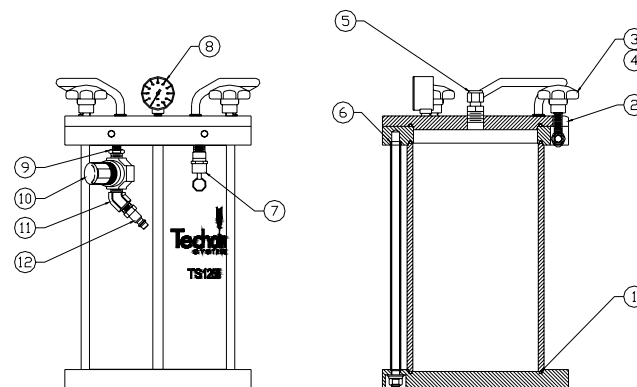

ITEM	PART NUMBER	DESCRIPTION	QTY
1	P3000034	O-RING, VITON 6.0" ID X 0.125 CS	3
2	T1000188	LID	1
3	A0100103	KNOB ASSEMBLY	3
4	TSD1144-14	SCREW, 8-32 X 0.625	6
5	P3000042	CONNECTOR, MALE 1/4"	1
6	P3000035	O-RING, BUNA 0.38" ID X 0.063 CS	3
7	P3000041	RELIEF VALVE	1
8	TSD600-33	PRESSURE GAUGE, 0-100 PSI	1
9	TSD915-1	REDUCER	1
10	TSD500-37	AIR REGULATOR	1
11	TSD916-2	STREET ELBOW FITTING	1
12	TSD356-8	QUICK DISCONNECT AIR FITTING	1

7. WARRANTY

OK International warrants this product to the original purchaser for a period of one (1) year from date of purchase to be free from material and workmanship defects but not normal wear-and-tear, abuse and faulty installation. Defective product or subassembly and components under warranty will be repaired or replaced (at OK International's option) free of charge. Customer with defective product under warranty must contact the nearest OK International office or distributor to secure a return authorization prior to shipping the product to the assigned OK International authorized service center.

For nearest OK International office or distributor contact information, please visit www.okinternational.com.

OK International reserves the right to make engineering product changes without notice.